

ARRI

535B Quick Guide

| | |
|--|-----------|
| Safety Specifications | 2 |
| Camera Left & Front..... | 3 |
| Camera Right & Back | 4 |
| 1. Quick Specs..... | 5 |
| 2. Status Indicators..... | 6 |
| 3. Loading Magazines | 7 |
| 4. Threading | 9 |
| 5. Power On, Camera RUN, Inching..... | 11 |
| 6. Changing Fps | 12 |
| 7. Changing Shutter Angle..... | 13 |
| 8. Timecode Sensitivity Table | 14 |
| 9. Arri Group Addresses..... | 15 |

Safety Specifications

About This Quick Guide

In order to ensure optimal performance, it is essential that you acquaint yourself with this Quick Guide and that you follow the operating instructions described herein. First time users must first acquaint themselves with the full 535B instruction manual. Even though all efforts have been made to ascertain the accuracy of this Guide, changes and upgrades to the products described can result in different hardware or behavior. In other words, technical data are subject to change without notice.

Best viewing and printing of the Acrobat (pdf) version of this Quick Guide can be achieved through the use of the Acrobat Reader 3.0 or later. For best printing results, use a PostScript printer. The Acrobat Reader can be downloaded for free from the Adobe web site at <http://www.adobe.com>.

Safety Specifications

- When transporting the camera, make sure that the sliding door securing the field lens is all the way down.
- Use only original ARRI accessories and replacement parts!
- Clean optical surfaces only with an optical brush or a clean optical cloth! In cases of solid dirt, moisten an optical cloth with pure alcohol (or brand-name lens cleaner).
- Do not use solvents when cleaning the film path!
- When adjusting the mirror shutter, turn the camera off and remove the power cable. Accidentally running the camera while adjusting the mirror shutter can cause great damage.
- Do not unscrew any screws which are sealed with locking paint!
- Never run the camera without a lens or a protective cap in the lens mount receptacle.
- Never place your hand in the lens cavity or the inside of the camera while the camera is running!
- Never open the movement or gate locking mechanism while the camera is running!

Camera Left & Front

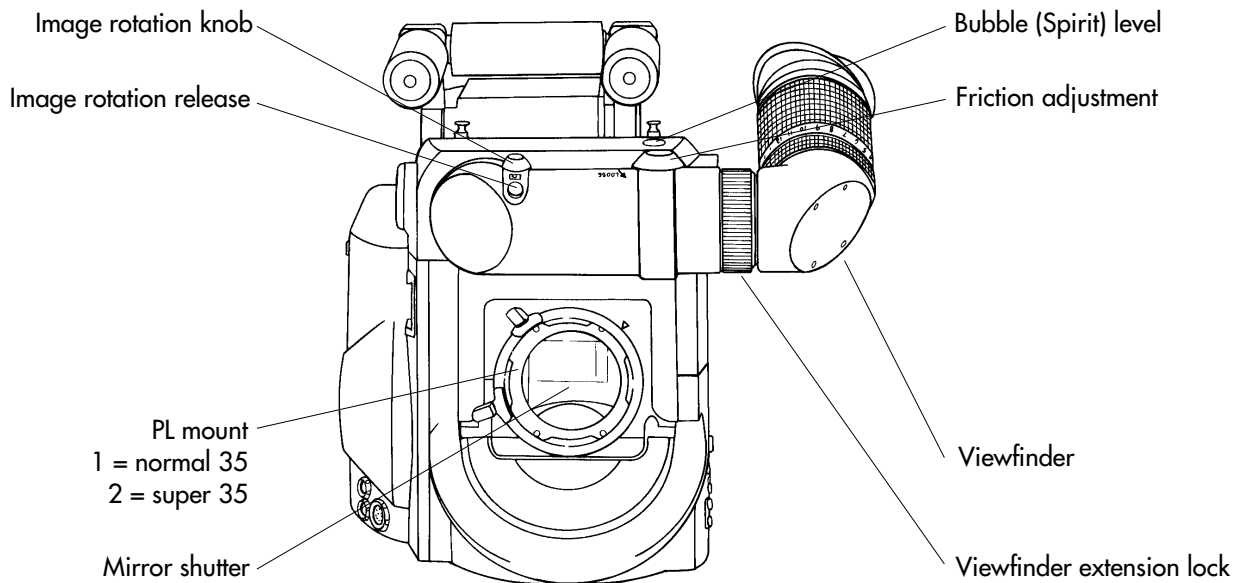
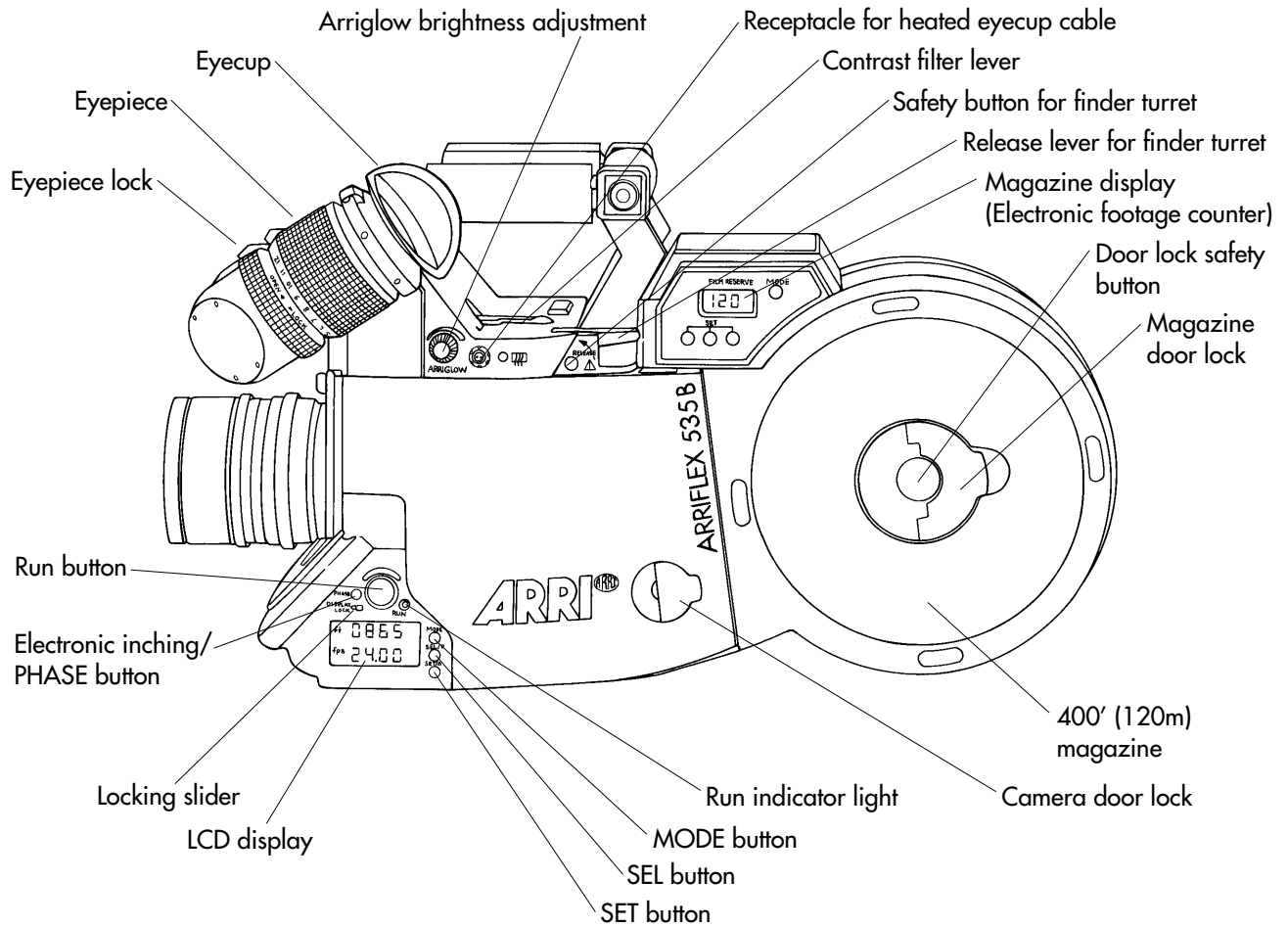

Camera Right & Back

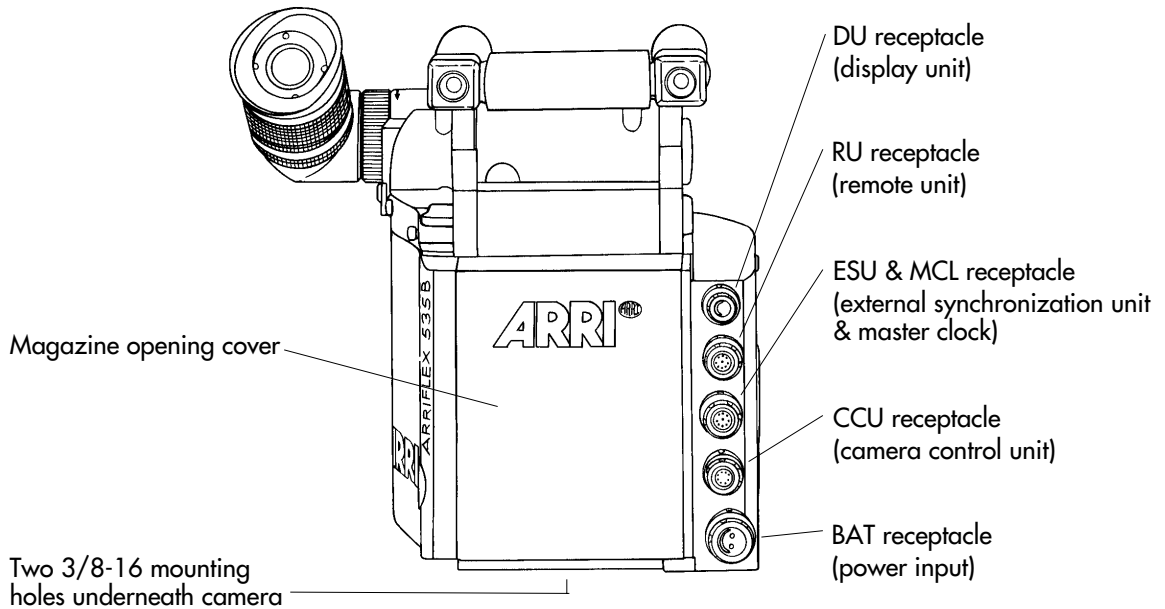
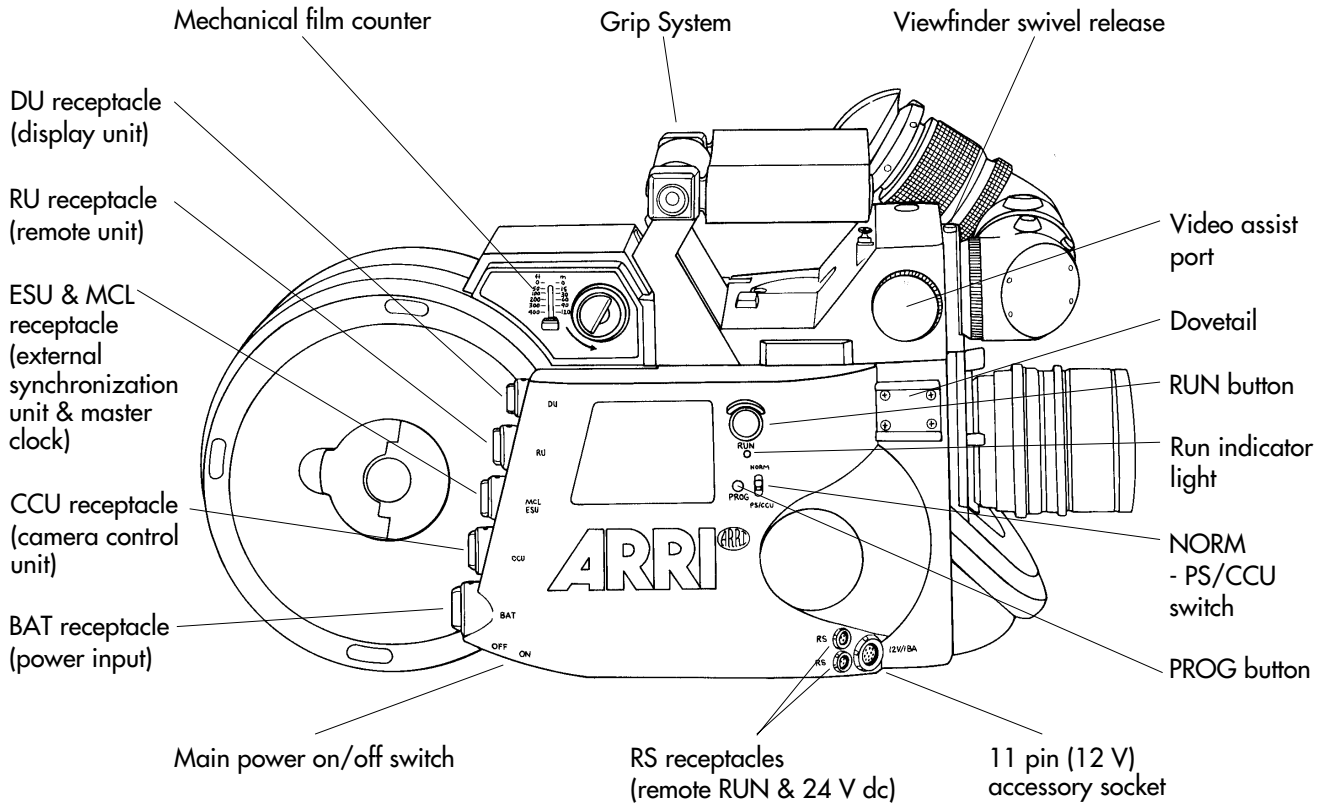

1. Quick Specs

| | |
|--------------------------------|---|
| Fps Range: | 3.000 to 60.000 fps, forward and reverse |
| Mirror Shutter: | 15.0° to 180.0°, manually adjustable Fixed settings at: every 15° from 15° to 135° and 144°, 172.8° and 180° |
| Power: | BAT: 24 V dc, Fischer connector, pin 1 is negative, pin 2 is positive Acceptable voltage range: 20 to 32 V dc RS: Pin 1: GND, pin 2: 24 V dc out, pin 3: /E-Run Power output: 24 V dc, 1 amp max. 11-Pin: Pin 9: GND, pin 11: 12 V dc Power output: 12 V dc, 1.8 amps max. Note: This 11 pin connector carries only power, it carries neither shutter pulse nor camera run capabilities. CCU: Pin 4: GND, pin 3: 24 V dc Power output: 24 V dc, 0.4 amps max. Fuses: Main fuse:15 A Picofuse Located on the left side of the electronics cover. The main fuse can only be accessed when the magazine is removed. Coaxial magazine fuse F1: 3 A Picofuse Coaxial magazine fuse F2: 0.25 A Picofuse Lightweight magazine fuse: 3 A Picofuse Located underneath a cover in the magazine throat. |
| Movement: | Two pull-down film transport claws and two registration pins |
| Flange Focal Distance: | 51.98 - 51.97 mm |
| Temperature Range: | -4° Fahrenheit to +122° Fahrenheit (-20°Celsius to +50°Celsius) |
| Electronic Accessories: | Integrated Video System (IVS), Remote Control Unit (RCU-1), Laptop Camera Controller (LCC), Lens Control System (LCS), Wireless Lens Control System (WLCS), Iris Control Unit for speed/iris ramps (ICU-1), Remote On/Off Switch (RS-4), External Synchronization Unit (ESU-1) |
| Other Accessories: | 400' (120m) coaxial magazine, 400' (120m) lightweight magazine, 1000' (300m) coaxial magazine, a wide variety of zoom and prime lenses, shift & tilt lens system, viewfinder extenders, anamorphic viewfinder, heated eyecup, exchangeable ground glasses and arriglow masks, various matte box systems, various follow focus systems, right side handgrip, hand held shoulder supports, steadicam support bracket, lens light, accessory connector splitter boxes, timecode exposure module, batteries, power supply, geared head, varicon contrast control, obie light |

2. Status Indicators

Viewfinder Indicators: END blinking: Film end coming up in X feet/meters ("X" can be set by user)
END glows: Camera ran out of film
ASY: Asynchronous operation; camera is not running at set fps rate
BAT: Low battery (less than 20 volts). Exchange battery.

Display Indicators: TC glows: Timecode exposure is enabled and timecode is set
TC blinks: Timecode exposure is enabled, but not recording properly
bat: Low battery (less than 20 volts). Exchange battery.
asy: Asynchronous operation; camera is not running at set fps rate
end flashes: Film end coming up in X feet/meters ("X" can be set by user)
end glows: Camera ran out of film
fps flashes: ESU is not receiving a valid signal
PROG glows: Internal program is activated

Display Warnings: The LCD Display will indicate any situations that will prevent running the camera by changing one or more of its digits into underlines.

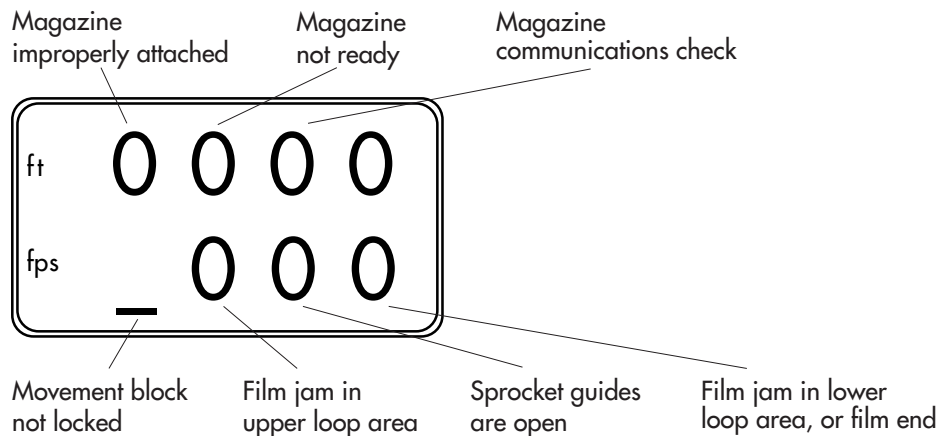

3. Loading Magazines

Always make sure that a loop protector is on the magazine when it is not on the camera. Also make sure that the magazine opening cover is on the camera when no magazine is attached to the camera. These instructions pertain to the coaxial magazines. To learn how to load the light weight magazine LM-1, refer to the 535B manual.

Step 1: The Feed Side

Load unexposed film only in absolute dark - such as in a dark room or changing bag.

- Take the loop protector off.
- Press the safety button on the feed side door and flip the magazine door lock up. Turn it counter clockwise until it stops and remove the door. Place the door with the interior face down beside the magazine. Turn the magazine door lock now clockwise and flip it down, so the film can be placed on the door.
- Flip up the hinged clip on the feed shaft.
- Remove the film from the film container.
- Remove the tape from the film end. Make sure that the tape is completely removed.
- Place the film roll on the magazine door.
- Guide the film head into the opening and carefully push it further until you feel it emerging from the upper magazine throat opening. If the film cannot be pushed through easily, employ the threading aid by flipping it up and then turning it counter clockwise to advance the film.

Note: Ensure that the threading aid is flipped back into position. Otherwise it can cause noise.

- Now place the film on the feed shaft and push the film core down as far as it will go, without pressing on the film itself. The film will otherwise become conical and cause noise.
- Flip down the hinged clip to lock the film core on the feed shaft.
- Open the magazine door lock, place the magazine door on the magazine and lock it. Double check by pulling up on the door.

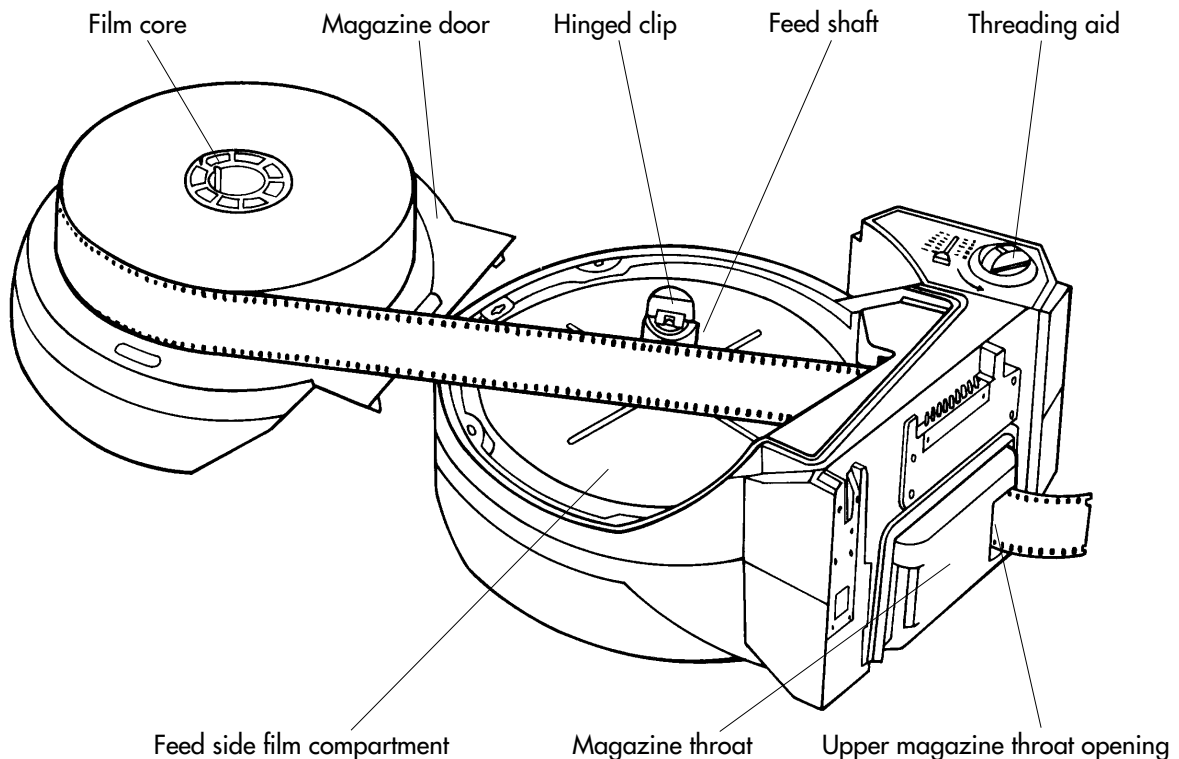

Step 2: The Take-up Side

Step 2 can be performed in daylight.

- Press the safety button on the take-up side magazine door and flip the door lock up. Turn the door lock counter clockwise until it stops and remove the magazine door.
- Slide the film head into the lower magazine throat opening until it emerges inside the take-up side.

Note: The loop-length is unimportant at this stage. It will be set once the magazine is on the camera.

- Place the head of the film into the collapsible core, clamp it in place and wind clockwise a couple of turns.
- Put the magazine door back on the magazine and lock it. Double check by pulling up on the door.

Step 3: Setting the Film Counter

Film amount loaded can be programmed into the magazine display. This value will be stored independently of the camera. During camera run, the magazine display will count down the loaded film. This value is also communicated to the camera and serves as a basis for the remaining film display and film end warning.

- Activate the magazine display by pressing the MODE button until "ft" or "m" appear in the display.
- Press the left SET button to increase the counter value by 100. Press the center SET button to increase the counter value by 10. Press the right SET button to increase the counter value by 1.

If you have loaded a full roll of film, you can quickly enter 393' (120m) by pressing the left and right SET buttons simultaneously on a 400' (120m) magazine, or 983' (300m) by pressing the left and right SET buttons simultaneously on a 1000' (300m) magazine.

- When using timecode, now is a good time to set the proper timecode sensitivity (TCS) value. Press the MODE button until the letters "TCS" appear in the display. Pressing any of the three SET buttons will increase the TCS value by 1. See the table at the end of the Quick Guide for the proper TCS values.

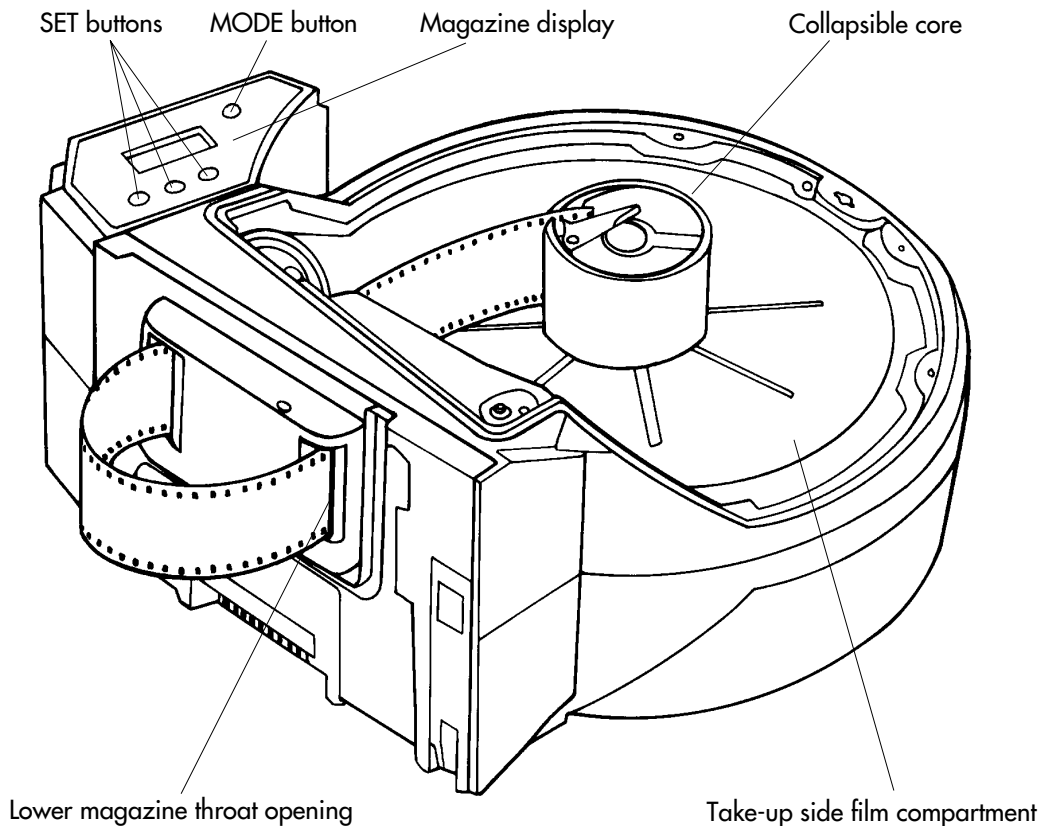

4. Threading

Mounting the Magazine

Attaching a magazine to the camera and threading film is done in the same manner with the coaxial and with the lightweight magazines.

Note: On the 535B the movement block is disengaged from the drive system when it is swung away from the gate. Both the movement and the drive system can now be turned independently of each other. However, the movement block can only be returned to the front position if it is properly re-aligned with the drive system. To re-align the movement block, press the inching button. If the camera is without power, you can slowly turn the knurled discs on the sprocket rollers - without pushing them in - until the movement block will swing forward freely.

Attaching the Magazine to the Camera

- Open the camera door and remove the magazine opening cover.
- Turn the inching knob on the movement until the white index line aligns with the LOADING POSITION line.
- Push the movement locking lever to the UNLOCK position and swing the movement block away from the film gate.
- Turn the sprocket guide lever up, towards the OPEN position.
- Pull some film out of the magazine until the loop is about 1 foot long.
- Push the loaded magazine halfway into the dovetail guide on the camera.
- Place the film in the movement so that it lies between the sprocket guides and the sprocket rollers, and between the movement and the film gate (see graphic on the next page).
- Push the magazine into the camera as far as it will go. The magazine will lock with an audible click.

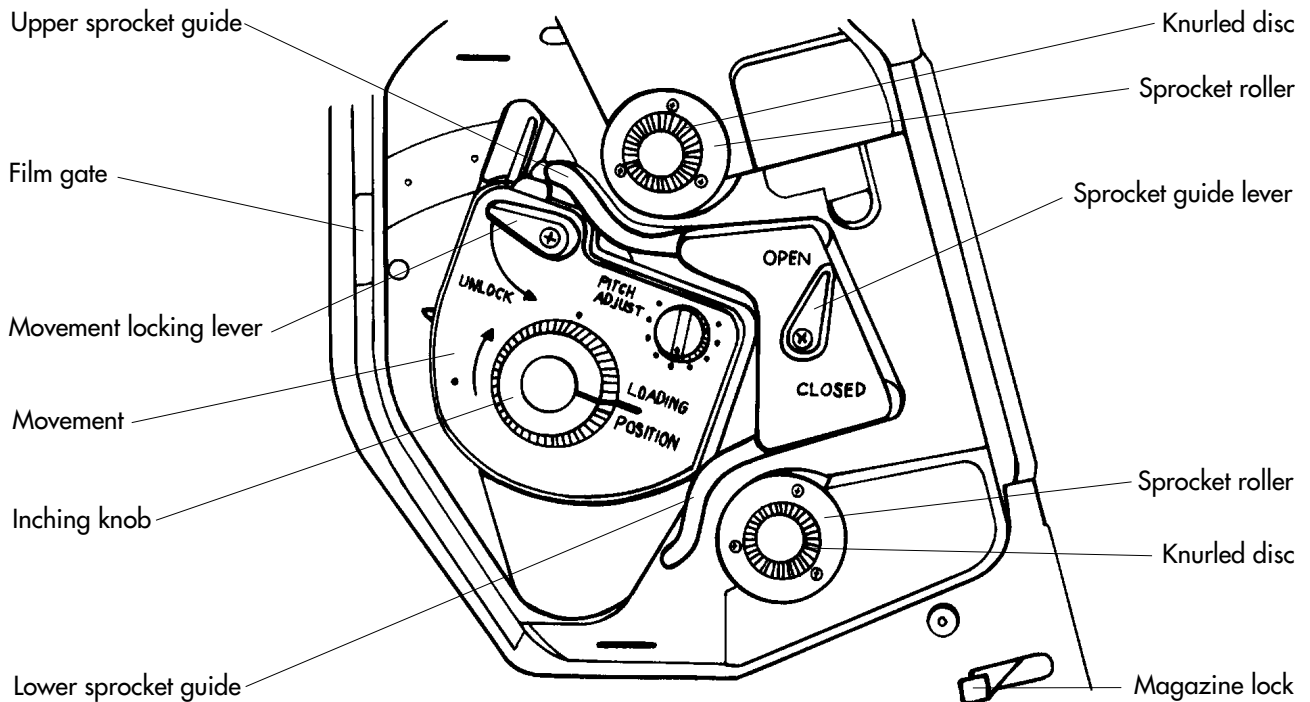

Threading the Film

- Position the film on the upper and lower sprocket rollers so that the sprockets engage the film perforations. Gravity will hold the film in place on the lower sprocket roller, but you may have to lift the upper film loop a little to hold the film on the upper sprocket roller. Close the sprocket roller guides by turning the sprocket guide lever towards the CLOSED position.

Note: If you cannot easily close the sprocket guide lever, it is an indication that the sprockets do not engage the film perforation properly. Open the sprocket guide lever again and reposition the film. Never force the sprocket guide lever!

- The white index line on the inching knob should still align with the LOADING POSITION on the movement.
- Push the movement locking lever to the UNLOCK position and gently swing the movement forward towards the film gate. Simultaneously slide the film a little up and down to ensure that the transport claws engage the film perforations.
- Set the upper and lower film loop to the corresponding film loop markings by pushing down on the knurled discs and turning them.
- To check for proper film transport, turn the inching knob in the direction of the arrow on the movement (clockwise).

Setting the Camera Counter

- Reset the TOTAL film counter by pushing the SET button for approximately 3 seconds when viewing the TOTAL counter on the LCD display.

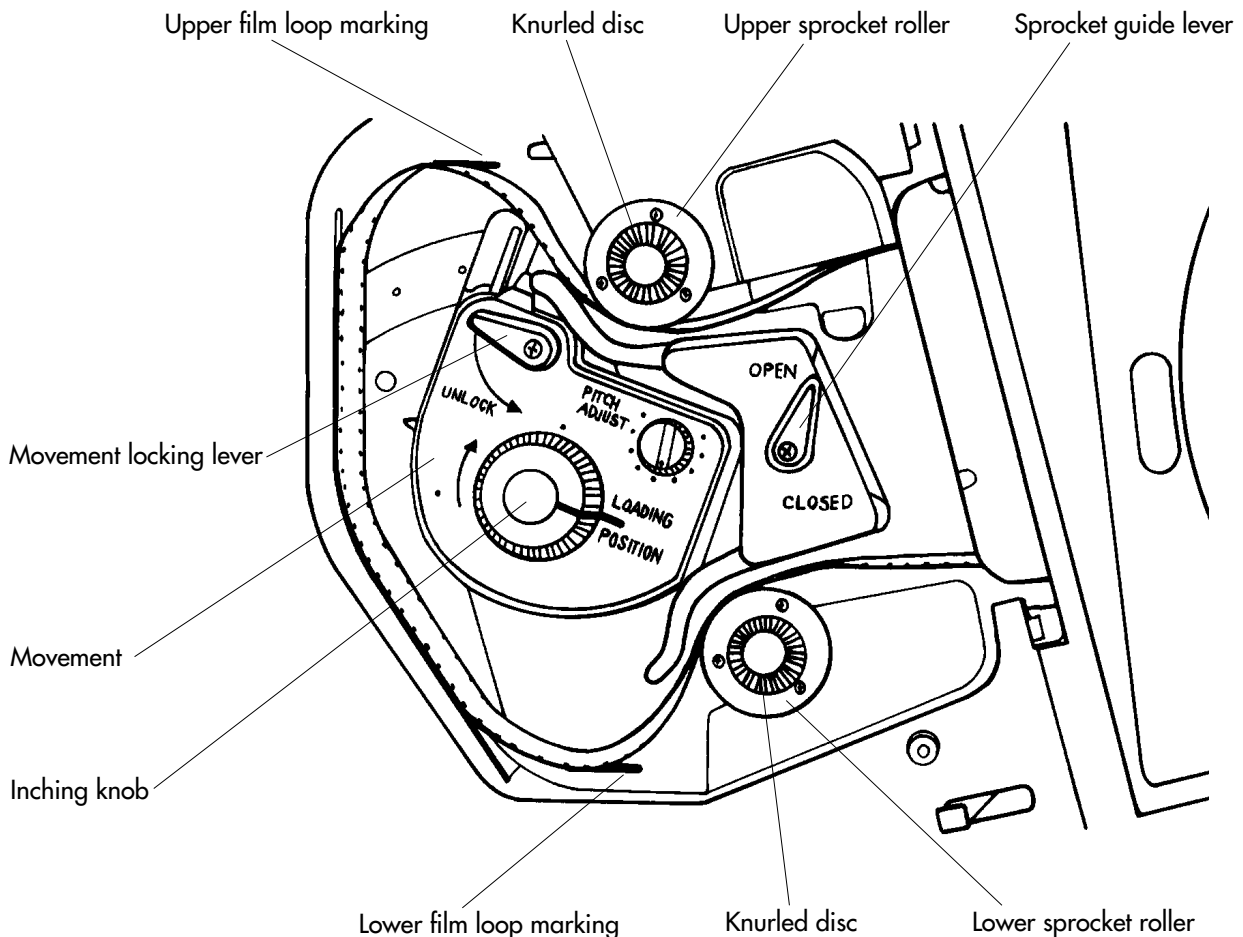

5. Power On, Camera RUN, Inching

Turning Camera Power On

The main power switch for the ARRIFLEX 535B is located on the underside of the electronics cover. When a battery is attached to the camera and the main power switch is turned on, you should see characters appear on the LCD display on the camera left side.

Camera RUN/STOP

A RUN button is located on both sides of the camera. To run the camera, depress the RUN button briefly. The RUN indicator light will glow red while the camera is coming up to speed, and switch to green once the set frame rate is reached. The RUN indicator light will steadily glow green when the camera is running without any problems at the set frame rate. If the RUN indicator light glows red when the camera is in Standby, the camera is not ready and pushing the RUN button will have no effect.

Inching

The ARRIFLEX 535B can be inched manually with the inching knob or electronically with the PHASE button. The PHASE button, if pushed very briefly, will also rotate the mirror shutter 180°. This allows for a fast gate check. To move the mirror shutter back in the viewing position, push the PHASE button again briefly.

- To manually inch the camera, open the camera door and turn the inching knob on the movement in the direction of the arrow (clockwise).

Note: Any film in the movement area will be exposed to light!

- To electronically inch the camera, press the PHASE button while the camera is in Standby.

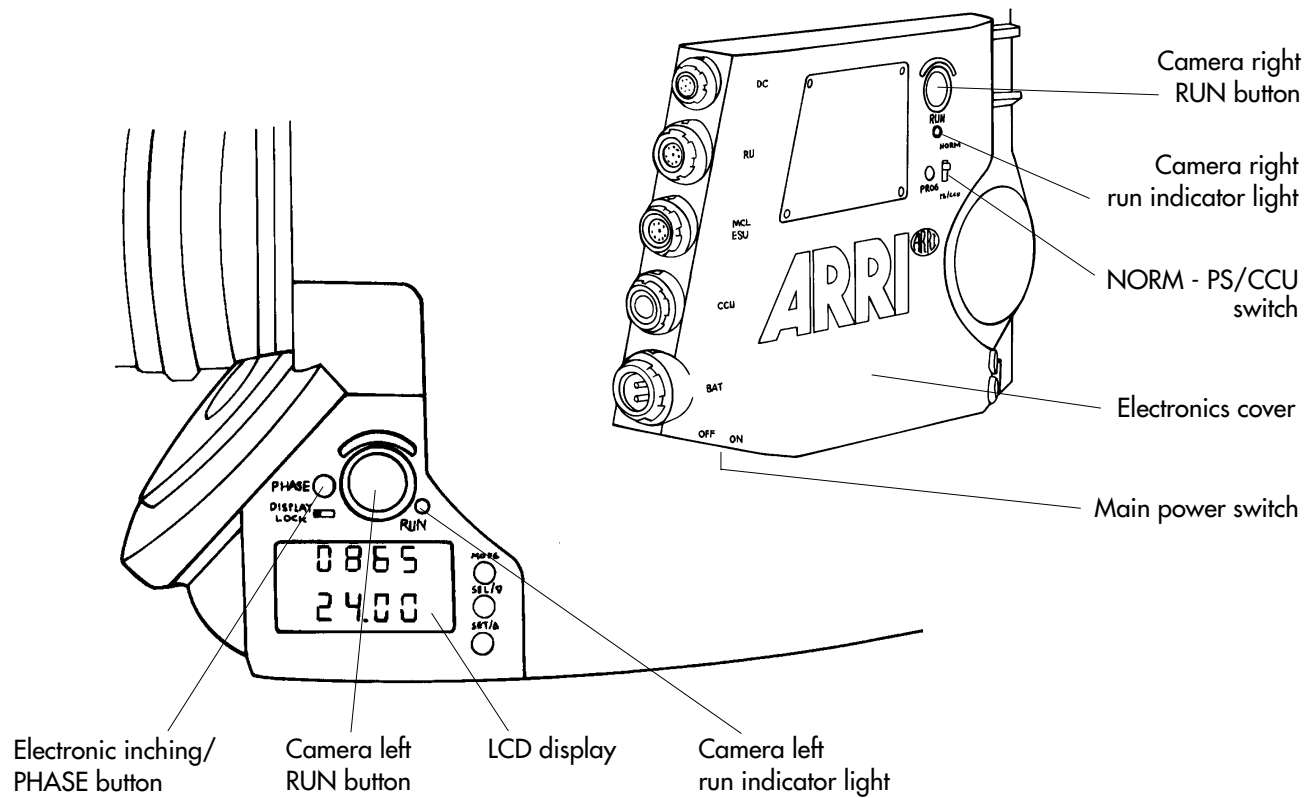

6. Changing Fps

With the NORM - PS/CCU switch on the camera's right side in the NORM position, the standard speeds 24, 25, 29.97 and 30 fps can be run. In the PS/CCU position, any speed from 3.000 to 60.000 fps, forward or reverse, can be run. All speeds set on the camera are crystal speeds.

Setting a Standard Speed

- Ensure that the locking slider is in the unlocked (right) position.
- Make sure the LCD display is in mode 1.
- Push the SEL button to cycle through the available standard speeds 24, 25, 29.97 and 30 fps. Each speed will flash for about 3 seconds.
- While a speed is flashing, push the SET button to set it.

Note: Set the NORM - PS/CCU switch to NORM to run the camera at the set standard speed.

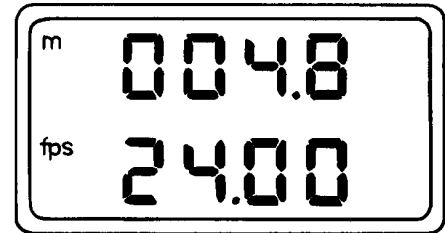

LCD display in mode 1.
Current frame rate set at 24 fps.

Setting a Programmable Speed (PS)

- Ensure that the locking slider is in the unlocked (right) position.
- Push the MODE button once to change from mode 1 to mode 2 ("PS" - programmable speed).
- Press the SEL button to select one digit after the other. A selected digit will blink. Press the SET button to increment the value of a flashing digit by one. Repeat this procedure for all digits that need to be changed.

The display will show full frame speed plus three digits past the decimal point. The 1/1000 th of a fps is displayed in the upper right-hand corner of the display.

Note: Set the NORM - PS/CCU switch to NORM to run the camera at the set standard speed.

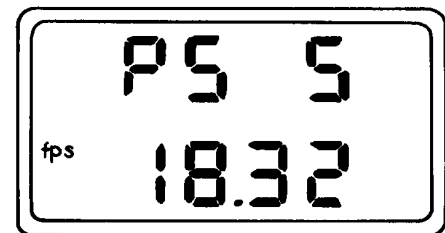

LCD display in mode 2.
Current frame rate set at 18.325 fps.

Note: One SEL button push beyond the 1/1000th fps is the setting that allows for reverse running (cd). Since it is fairly easy to change, be careful not to accidentally set the camera to run in reverse when changing the programmable speed. Always double check!

Setting the Camera to run in Reverse

- Ensure that the locking slider is in the unlocked (right) position.
- Push the MODE button once to change from mode 1 to mode 2 ("PS" - programmable speed).
- Press the SEL button repeatedly until "cd" (camera direction) blinks.
- Change the running direction of the camera now with the SET button. When the camera is set to run in reverse, a minus sign is displayed in front of the "PS" symbol.

Note: This minus sign is the only indication that the camera will run in reverse. Pay close attention!

Note: Camera direction will be set to reverse for the standard speeds (NORM) and for the programmable speeds (PS).

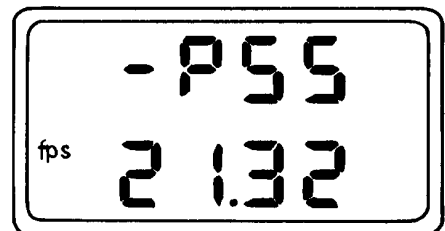

LCD display in mode 2.
Current frame rate set at reverse
21.325 fps.

7. Changing Shutter Angle

Checking the Mirror Shutter Angle

- Make sure that the camera is in standby.
- Push the PHASE button and keep it held down. The camera will run at the inching speed (1 fps).
- After two seconds the top line of the LCD display will show the open angle of the mirror shutter.

Note: The camera will not inch electronically (PHASE button) when it is set to run in reverse.

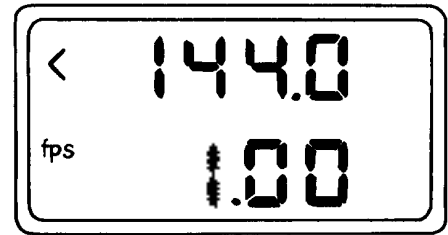

LCD display in mode 1.
Open mirror shutter angle (144.0°)
visible during electronic inching.

Changing the Mirror Shutter Angle

Note: Before adjusting the mirror shutter, turn the camera off and remove the power cable! Accidentally running the camera while adjusting the mirror shutter can cause great damage.

- Remove the lens or lens mount cavity cap.
- Turn the inching knob on the movement until the adjustment screw and the shutter lock are visible in the lens opening (see graphic). You may have to hold the inching knob while adjusting the shutter to keep the shutter in place.
- Use a 2 mm hex driver to turn the shutter lock (labeled CATCH) towards the LOOSE position. You will see a small tab (called a "catch") disengage from a cut out in the locking ring.
- Use the 2 mm hex driver to turn the adjustment screw. You will see the shutter blade turn out from under the mirror. Position the shutter blade at one of the labeled default positions.
- Turn the shutter lock now with the 2 mm hex driver back towards the LOCK position, until you see the catch snap into a cut out.

Note: When you close the shutter down, you have to compensate your exposure. Open up the lens aperture one stop for a 90° and two stops for a 45° shutter angle.

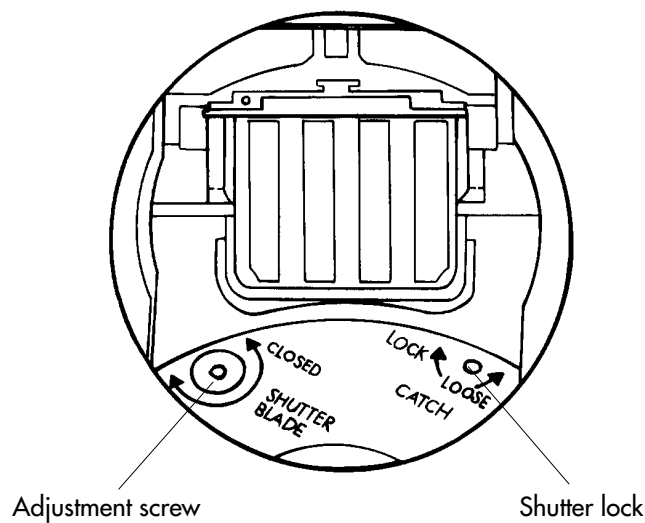

8. Timecode Sensitivity Table

Notes

This table is in effect as of January 1998. The latest information can be found in the ARRI Technical Note P-1002 on the ARRI website at <http://www.arri.com>.

All the new generation Arriflex cameras are able to record SMPTE Timecode as a barcode on film. In order to ensure the proper exposure of this barcode, the assistant has to set a "Timecode Sensitivity" (TCS) number. The TCS number indicates the sensitivity of a given film stock to the wavelength of light produced by the LED that exposes the film. The TCS number is set either on the magazine (535A, 535B, 16SR 3) or on the camera directly (435, 435ES).

Timecode recording is possible at the standard speeds of 23.976, 24, 25, 29.97 and 30 fps. Some 535s cannot record Timecode at 23.976, but can be modified to do so by any authorized Arri service facility.

No Timecode will be recorded if TCS is set to "0".

35 mm Kodak Film Stocks

| <i>Emulsion</i> | <i>Type</i> | <i>TCS</i> |
|-----------------|----------------|------------|
| 5222 | B/W Negative | 8 |
| 5224 | B/W Reversal | 8 |
| 5231 | B/W Negative | 8 |
| 5239 | Color Reversal | 6 |
| 5240 | Color Reversal | 5 |
| 5245 | Color Negative | 7 |
| 5246 | Color Negative | 6 |
| 5248 | Color Negative | 7 |
| 5274 | Color Negative | 6 |
| 5277 | Color Negative | 5 |
| 5279 | Color Negative | 5 |
| 5287 | Color Negative | 6 |
| 5293 | Color Negative | 6 |
| 5294 | Color Negative | 5 |
| 5295 | Color Negative | 4 |
| 5296 | Color Negative | 5 |
| 5297 | Color Negative | 5 |
| 5298 | Color Negative | 5 |
| 5620 | Color Negative | 5 |

35 mm Fuji Film Stocks

| <i>Emulsion</i> | <i>Type</i> | <i>TCS</i> |
|-----------------|----------------|------------|
| 8510 | Color Negative | 7 |
| 8514 | Color Negative | 5 |
| 8520 | Color Negative | 5 |
| 8521 | Color Negative | 7 |
| 8530 | Color Negative | 6 |
| 8531 | Color Negative | 7 |
| 8550 | Color Negative | 4 |
| 8551 | Color Negative | 6 |
| 8560 | Color Negative | 6 |
| 8561 | Color Negative | 5 |
| 8570 | Color Negative | 6 |
| 8571 | Color Negative | 5 |

35 mm Agfa Film Stocks

| <i>Emulsion</i> | <i>Type</i> | <i>TCS</i> |
|-----------------|----------------|------------|
| PAN 250 | B/W Negative | 7 |
| XT 100 | Color Negative | 6 |
| XTR 250 | Color Negative | 5 |
| XTS 400 | Color Negative | 5 |

9. Arri Group Addresses

Canada:

ARRI Canada Limited

415 Horner Ave. Unit 11, Toronto, Ontario M8W 4W3, Canada
Voice phone: +416 255 3335, FAX: +416 255 3399
Email: email@arrican.com

Germany:

Arnold & Richter Cine Technik

Türkenstraße 89, D-80799 Munich, Germany
Voice phone: +49 (0)89 3809-0, FAX: +49 (0)89 3809-1244
Email: webmaster@arri.de

ARRI Leihpark (Film Equipment Rental Germany)

Türkenstraße 89, D-80799 Munich, Germany
Voice phone: +49 (0)89 3809-1240, FAX: +49 (0)89 3809-1798
Email: rwiesmann@arri.de

England:

ARRI GB Ltd Sales & Service

1-3 Airlinks, Spitfire Way, Heston, Middlesex, TW5 9NR, England
Voice phone: +44 (0)181 848 8881, FAX: +44 (0)181 561 1312
Email: sales@arri-gb.com

ARRI MEDIA (Camera Rental England)

4-5 Airlinks, Spitfire Way, Heston, Middlesex, TW5 9NR, England
Voice phone: +44 (0)181 573 2255, FAX: +44 (0)181 756 0592
Email: info@arrimedia.com

ARRI Lighting Rental

20A Airlinks, Spitfire Way, Heston, Middlesex TW5 9NR, England
Voice phone: +44 (0)181 561 6700, FAX: +44 (0)181 569 2539
Email: tross@arrilightingrental.com

Italy:

ARRI Italia S.r.l., Head Office (Milan)

Viale Edison 318, 20099 Sesto San Giovanni (Milan), Italy
Voice phone: +39 (0)2 262 271 75, FAX: +39 (0)2 242 1692
Email: info@arri.it

ARRI Italia S.r.l., Rome

Via Placanica 95, 00040 Morena (Rome), Italy
Voice phone: +39 (0)6 726 707 97, FAX: +39 (0)6 723 1541

USA:

Arriflex Corporation, East Coast

617 Route 303, Blauvelt, NY 10913-1109, USA
Voice phone: 914-353-1400, FAX: 914-425-1250
Email: arriflex@arri.com

Arriflex Corporation, West Coast

600 North Victory Blvd., Burbank, CA 91502-1639, USA
Voice phone: 818-841-7070, FAX: 818-848-4028
Email: brussell@arri.com

CSC Camera Service Center (Film Equipment Rental USA)

619 West 54th St, New York, NY 10019, USA
Voice phone: 212-757-0906, FAX: 212-713-0075
Email: aweeber@cameraservice.com

Information about the products discussed in this Guide and more can be found on the Arri website at:

www.arri.com